

LOGSET 6HP GTE

MEDIUM-SIZED FUEL SAVING HARVESTER

The Logset 6HP GTE is a medium-sized harvester that can be described as stable and fuel saving. It is a fast, agile, and strong machine designed for smaller thinning operations and medium-sized clear-fells. In such conditions it has the optimal productivity and the best economy.

COMPONENTS IN BALANCE

Thanks to its Mesera 221H crane, with an outreach up to 11 meters, the Logset 6HP GTE performs with ease in forests with small and medium diameter trees. The size of the engine, the hydraulics and the mechanical parts of the machine are perfectly dimensioned - making the Logset design optimal compared to other harvesters in its size class.

The Logset 6HP GTE can be equipped with the Logset TH45, TH55 or TH65 harvester head, all designed for easy and precise operation. The harvester head can be handled fast, yet precise.

EIGHT WHEELS FOR BETTER PERFORMANCE

The Logset 6HP GTE is a stable machine, which brings the operator comfort to a new level. The eight wheels provide the machine an outstanding performance on all terrains: excellent tractive power and stability in steep slopes and flotation for soft ground conditions. In short: when you mount tracks all round you can work where you couldn't go before.

ECONOMIC

With the fuel efficient 6-cylinder 7,4 l diesel engine, the Logset 6HP GTE has enough power and torque to push the 190 cm³ hydraulic pump. Due to the successful combination of the engine size, hydraulics and the new Logset TOC-MD 2, the engine is not strained and the operator notices this clearly in the low fuel consumption.

LOGSET GTE Harvester



Harvester range 12/19 - EN
We reserve the right to make changes without prior notice.
All technical specifications are for guidance only.
The pictures and diagrams do not always show standard versions of the machines.
Copyright Logset Oy.



LOGSET

LOGSET Oy
Hännisentie 2
FI-66530 Koivulahti
FINLAND
Tel. +358 10 286 3200

LOGSET
SIMPLY BETTER
www.logset.com

SIMPLY BETTER

LOGSET

Key features of the Logset harvester

HYDRAULIC TANK

The larger fuel tank means less down time for fuel filling and more productive time in the forest. The total volume of the fuel tanks is 500 litres. Also the hydraulic oil tank volume has been increased. The tanks can be tilted to the side when service access to the hydraulic pumps is required.

CABIN

The cabin has excellent all-round visibility. The upgraded work light guard protects the work lights and cabin roof even better. The new design decreases the transportation height and gives the cabin an eye-pleasing, round profile. The cabin's low noise level is a key factor for operator comfort.

CONTROL SYSTEM TOC-MD 2

Logset's own TOC-MD 2 measuring device for the harvester head maximizes the production and is easy to navigate and to use. The technology is thoroughly proven through the years. Features such as the adaptive feeding and cutting window search make the operator's work easier and the machine more productive.

CRANE

The strong 221H Mesera parallel cranes have an optimal geometry. The unique stability of the machine allows you to utilize the crane power within the entire reach area. It is fast, agile and reliable.



ENGINE

The powerful AGCO Power engines with SCR technology deliver high torque at low engine speed, offering the best fuel economy engine in their range.

TRANSMISSION

The transmission is controlled and optimized by the TOC 2 control system. The combination of reliable NAF-bogies both in the front and back and a powerful frame lock system which uses large hydraulic cylinders ensure the perfect stability of the harvester. Hydraulically balanced front bogies or mechanically balanced bogies all around are available as optional equipment.

HYDRAULICS

The Logset 6HP GTE offers 285 l/min at 1500 rpm, which is the correct flow for high productivity and better fuel economy. A right balance for the best output.

HARVESTER HEAD

The Logset TH harvester head is the key to higher productivity. The Logset 6HP GTE can be equipped with a Logset TH45, TH55 or TH65 harvester head, whichever size best meets the needs.

Technical data



MODEL	6HP GTE
DIMENSIONS	
Own weight, kg from	21 000 (46 300 lbs)
ENGINE (EUROPE)	
Type	AGCO Power 74 LFTN
Stage	Stage V
Power at 1 850 rpm, kW	190 (258 hp)
Torque at 1 500 rpm, Nm	1 130
Fuel tank, l	500
DEF, l	40
TRANSMISSION	
Type	Hydrostatic mechanical
Tractive effort, kN	169 (38 000 lbf)
Gear box	2 gears
HYDRAULIC SYSTEM	
Flow 1 000 rpm, l/min	190 (50 US gal)
Hydraulic oil tank, l	400 (106 US gal)
CABIN	
Control system	TOC 2
Measuring device	TOC-MD 2
Battery voltage	24 V
Safety tested and approved cabin • Rotating and levelling cabin (in option)	
TYRES	
Front	600/55-26.5; 710/45-26.6
Rear	600/55-26.5; 710/45-26.6
CRANE OPTIONS	
Crane	Mesera 221H
Lifting capacity, kNm	188 (138 660 ft lb)
Reach options, m	8.3/10/11 (27/33/36 ft)
HARVESTER HEADS	
Model options	TH45, TH55, TH65
OPTIONAL EQUIPMENTS Contact your local dealer for more information about options	

LOGSET 6HP GTE

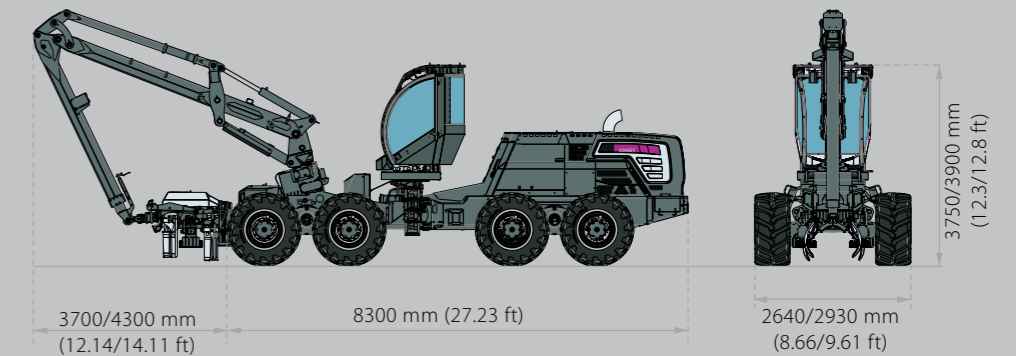

SIMPLY BETTER

LOGSET